

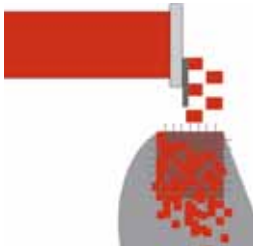

Dicing, cutting strips, grating – with TWISTER



The AVS (automatic pre-compression system) facilitates an optimal dimensional accuracy of the dices and strips right from the beginning.



Goulash cubes are of course part of the cutting repertoire of the TWISTER.

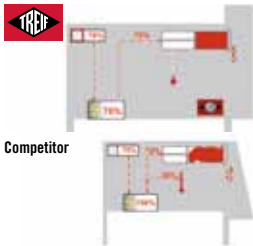

Competitor

As a result of the patented DHS (Dynamic Hydraulic System), the cut products stay fresh longer (the machine generates less heat, so there is less of a chance for bacteria to form).



Cooked products, like poultry in this example, can also be cut with ease.



The separating slide operates in a curving motion. This enables user-friendly, one-hand operation.



TWISTER is very versatile. The different cutting parameters can be saved (up to 50 cutting programs).

In one hour the dice and strip cutting machine achieves a max. output of up to 3,500 kg (theoretical maximum value), even during constant operation.



Excellent cutting results thanks to the patented gentle cut gridset (optional). This ensures the best possible cutting geometry for excellent cutting results.



The dice and strip cutting machine can process up to 3.5 t in one hour (theoretical maximum value). The blade revolution speed can be individually set.

It can handle highest stresses, even with respect to the loading. TWISTER can be optionally fitted with a convenient and reliable lift for E-boxes. For the operator that means: At last, no more straining bending and heavy, strenuous lifting.

Gentle cut

With the help of the gentle cut gridset (optional), delicate products such as cooked meat, poultry or boiled sausage are cut gently, thus achieving excellent cutting results.

Technical data:

Max. output t/h (Theoretical maximum value)	3.5; 7,716 lbs
Max. cut-off length (mm/inch)	1–50; 1/25"–2"
Max. cut-off blade speed/min.	300/400 (TWISTER G)
Housing dimensions (mm/inch)	
Length/Width/Height with lift and outlet conveyor (mm/inch)	1,902/1,800/1,282; 74 4/5" / 71" / 50 1/2"
Connecting load (kW)	4.5 (TWISTER G: 6.0)
Gridsets (mm/inch)	4/5/6/8/10/12/15/17/20/24/30/40/60/120; 1/5" ; 3/10" ; 2/5" ; 1/2" ; 3/5" ; 7/10" ; 4/5" ; 1" ; 1 1/5" ; 1 3/5" ; 4 7/10"
Weight with lift & outlet conveyor (kg/lb)	approx. 670; 1,477
Product specific accessories	on request

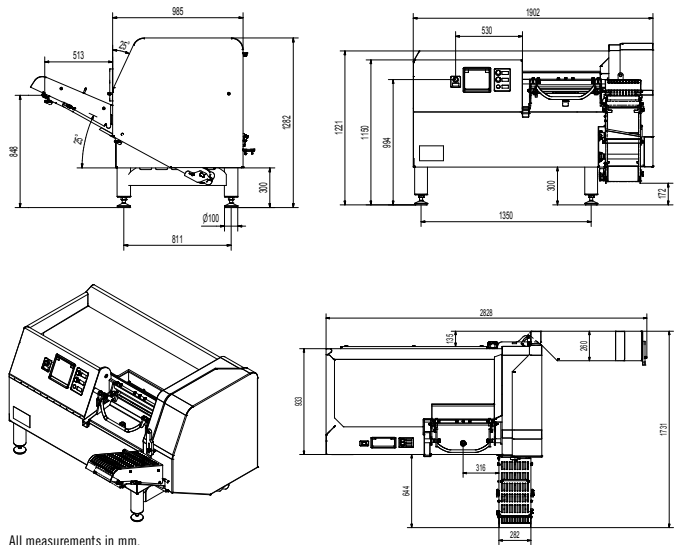

All measurements in mm.



Cleaning channel for a better flow of liquids, e.g. meat juice, rinsing water.



For dicing cheese a special cheese grid is used.



TWISTER can also be fitted with a scale.

Your benefits at a glance:

- Semi-automatic loading
- Flexibility and top performance thanks to continuous and intermittent cutting options and the ability to individually set the blade speed
- Optimum product compression as a result of the automatic pre-compression system (AVS)
- Ergonomic, one-hand operating system for closing the loading chamber; chamber size: 550 x 120 x 120 mm / 21 7/10" x 4 7/10" x 4 7/10" (length x width x height)
- Patented gentle cut gridset for delicate products (optional)
- Reliable protection against the hydraulic oil of the feed cylinder entering the cutting chamber; patented hygiene cylinder (optional) makes product contamination with hydraulic oil (only foodstuff hydraulic oil is employed at TREIF) technically impossible

www.treif.com

HEADQUARTERS:

TREIF Maschinenbau GmbH
Südstraße 4
D-57641 Oberlahr
Tel. +49 2685 944 0
Fax +49 2685 1025
E-Mail: info@treif.com

LOCATIONS:

TREIF S.A.R.L.
22, rue des Tuileries
F-67460 Souffelweyersheim
Tel. +33 3 8818 4018
Fax +33 3 8818 4019
E-Mail: info-france@treif.com

TREIF USA Inc.
50 Waterview Drive, Suite 130
USA-Shelton CT 06484
Tel. +1 203 929 9930
Fax +1 203 929 9949
E-Mail: treifusa@treif.com

TREIF U.K. Ltd.
4 Europa Park
Croft Way Eastways
GB-Witham Essex CM 8 2FN
Tel. +44 1376 504060
Fax +44 1376 504070
E-Mail: info@treif.co.uk

TREIF in Belgium
Villalaan 21
B-9320 Aalst
Tel. +32 53 770813
Fax + 32 53 789666
E-Mail: jo.luybaert@treif.com

TREIF China
TREIF Maschinenbau GmbH
Room 212, No. 188 Zhangyang Rd.
PRC-Shanghai, 200120 China
Tel. +86 21 5879 8255
Fax +86 21 5879 8256
E-Mail: treif.china@treif.com